

IEEC^R

Institut d'Estudis
Espacials de Catalunya

CERCA

Centres de Recerca
de Catalunya



Generalitat
de Catalunya

IEEC missions

5th February 2025

www.ieec.cat
[@IEEC_space](https://twitter.com/IEEC_space)



UNIVERSITAT DE
BARCELONA

UAB
Universitat Autònoma
de Barcelona



UNIVERSITAT POLITÈCNICA
DE CATALUNYA
BARCELONATECH



CSIC
CONSEJO SUPERIOR DE INVESTIGACIONES CIENTÍFICAS



Space missions

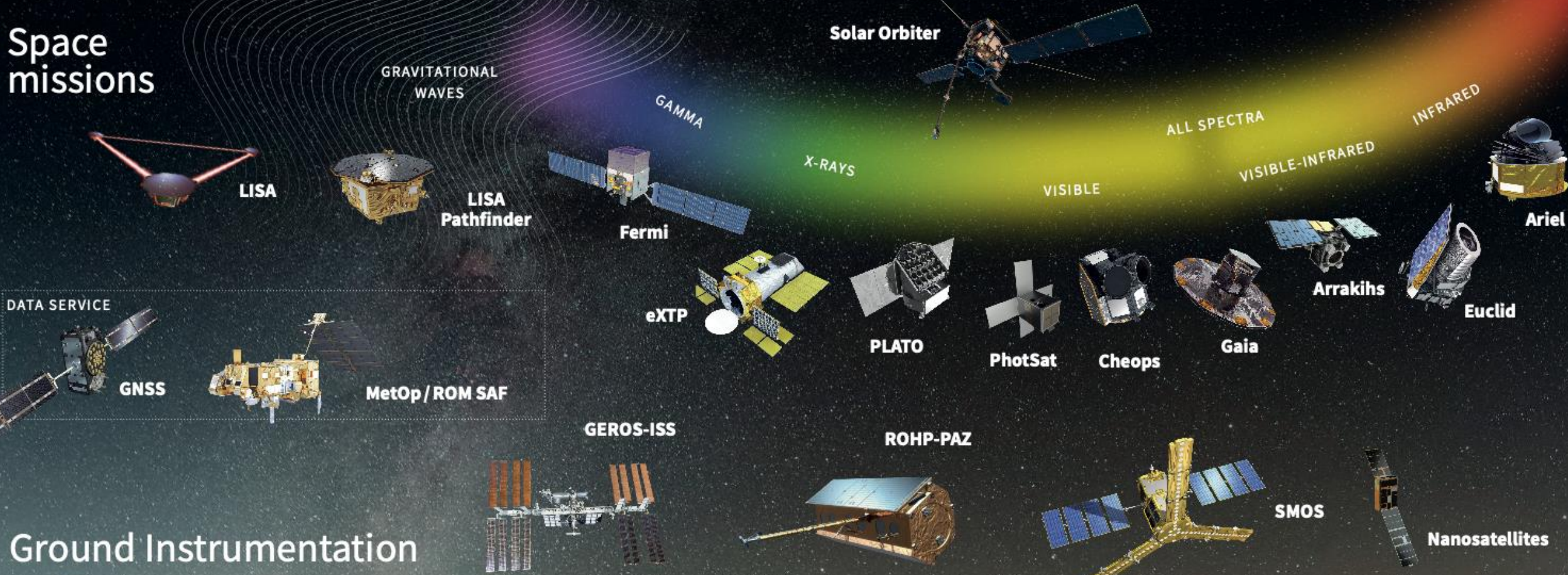

Ground Instrumentation



Joan Oró telescope (TJO)

IEEC[®]

Institut d'Estudis Espacials de Catalunya



LISA – IEEC contribution



MINISTERIO DE CIENCIA, INNOVACIÓN Y UNIVERSIDADES



Cofinanciado por la Unión Europea



Laser Interferometer Space Antenna

- **Mission:** First gravitational wave detector in space. Consists of a constellation of three spacecrafts in formation flying. **Planned launch:** 2035.
- **Partnership:** Led by ESA with collaboration of NASA, and an international consortium of scientists (the LISA consortium). Spain is amongst the main four national contributions which are providing the payload.

IEEC Contribution (leading the Spanish contribution)

- Deliver the **Science Diagnostics Subsystem (SDS)** : 144 temp. sensors, 18 AMR magnetometers, 3 radiation monitors, 12 heaters, 3 audio band EM sensors and of sensors and 6 Data Acquisition and Control Units (DACUs; developed by Sener through a PRODEX contract)

The SDS → characterize and monitor: MOSA thermal environment, test mass magnetic environment in low frequency and audio frequency and radiation environment and generate science data information during science mode

- Science team works on the Spanish DCC and Global Fit Pipeline → from L1 data (after the TDI) to L2 data (catalogue of gravitational wave sources and noise model with the probability distributions of the parameters)

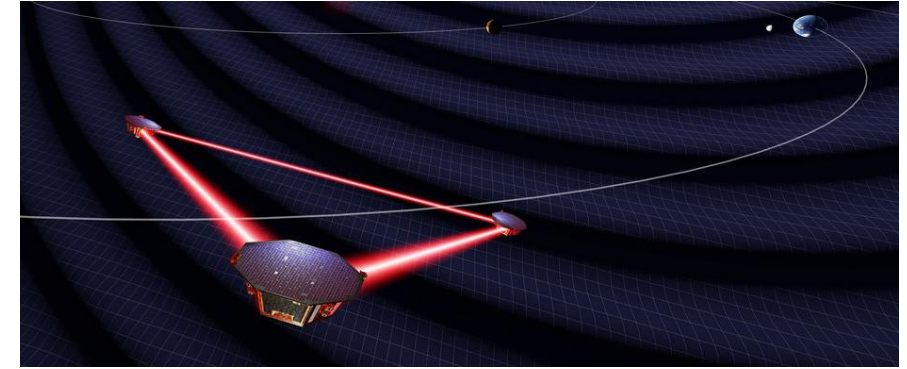

Illustration of the LISA mission concept

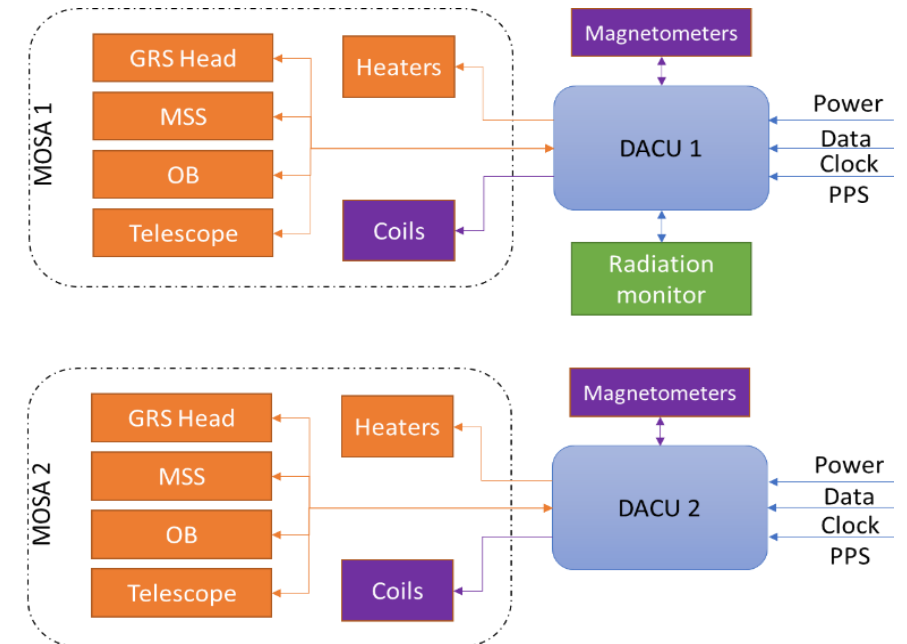

Illustration of the hardware contribution to LISA for one spacecraft



Ariel – IEEC contribution

Atmospheric Remote-sensing Infrared Exoplanet Large-survey

- **Mission theme:** Performing a chemical census of a large and diverse sample of exoplanets by analyzing their atmospheres. **Planned launch:** end 2029
- **Partnership:** ESA and the Ariel Mission Consortium. Involves 50+ institutes from 17 European countries and NASA. The Consortium will provide the payload module: reflector telescope and associated science instruments.



Render of the Ariel telescope



Render of the TCU model (left) and the M2M (right)

IEEC contribution (coordinating the Spanish Contribution)

- Provide the **telescope control unit (TCU)** controlling the M2M
- Oversee the **secondary mirror mechanism (M2M)** activities, performed within a PRODEX contract by Sener Aeroespacial
- Provide the **scheduler** for the GSE, a mission planning tool that optimizes the observation timeline from transit ephemeris
- Science team members playing a crucial role in **optimizing target selection** and implement **stellar activity correction methodologies** as part of the Ariel WPs

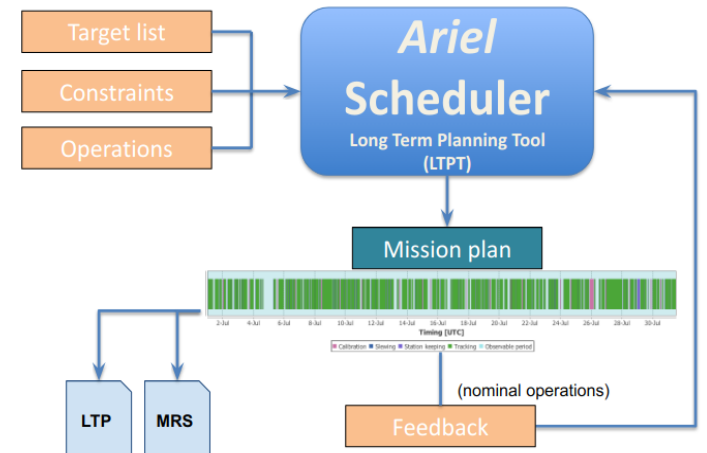

Ariel scheduler LTPT diagram

PhotSat mission

PhotSat



Generalitat
de Catalunya



PLANES COMPLEMENTARIOS



Astrofísica y física
de altas energías

- All-sky monitoring of the 10 million brighter stars ($V < 12$) and other astrophysical objects
- Main science case to support high-precision programmes of all kinds (exoplanets, solar system, stars, extragalactic, transients)

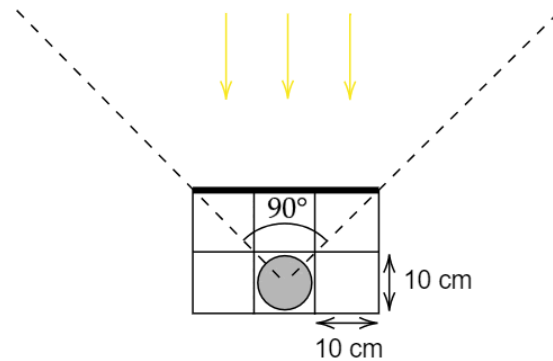
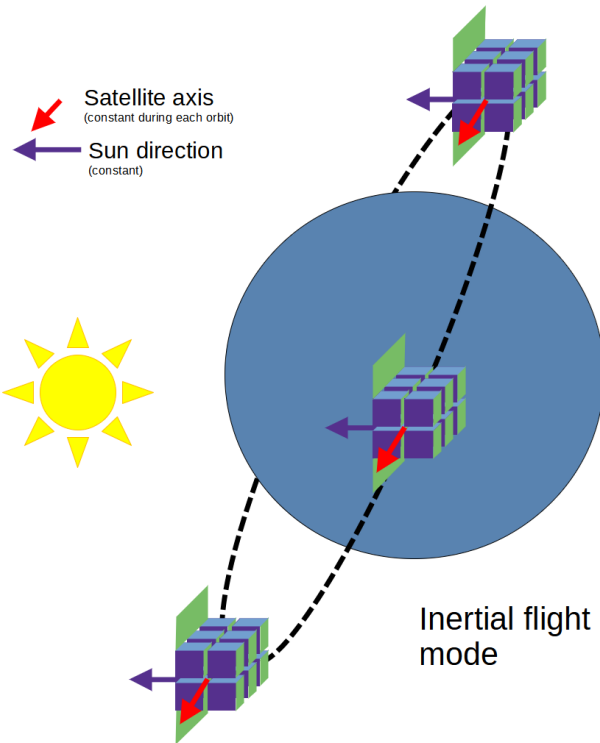
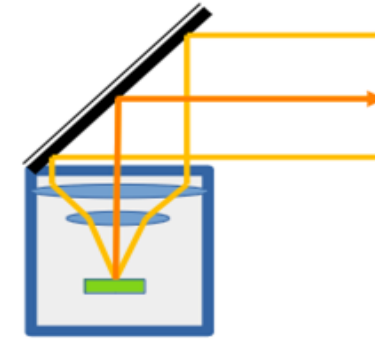

- 16U platform
- Detector: 2k x 2k, 6.5 μm pixel
- CMOS, constant image rate 1 Hz
- Sampling: 14"/pix, pointing stability $< 5''$
- Two cameras: 250-350 nm UV, 500-840 nm VIS – V&R; FoV: 8 deg
- Full sky covered in 2 days
- Sun avoidance angle 45 deg
- Launch in Q4 2025 – Q1 2026